

Chrysler 68RFE

Smart-Tech[®] Overdrive Clutch Housing Kit

Part No.
72960-16K

- Overdrive/Reverse Housing
- Lip Seal
- Adapter Sleeve
- UD/OD Reaction Plate
- Steel Clutch Plates (5)
- Friction Clutch Plates (6) Custom BorgWarner
- Anchor Plate Shims (2)
- Bolt-On Anchor Plate
- Screws (12)
- Chisel Not Shown

Patent No. 10,480,592B1 with additional patents pending.

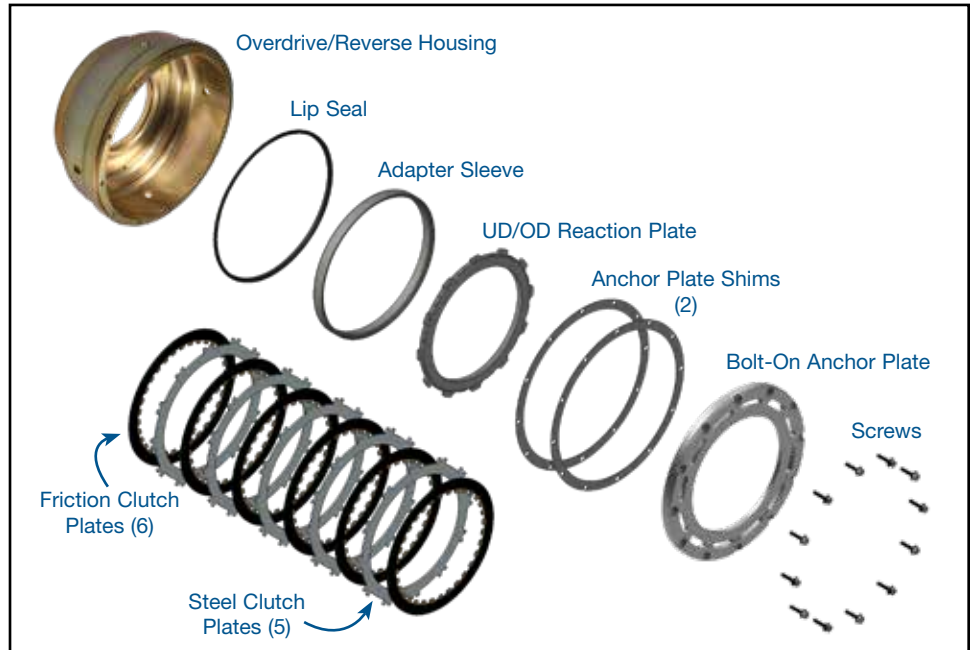

NOTE: Pre-soak overdrive frictions and steels in ATF+4 transmission fluid before final assembly. F+4 is the recommended fill oil.



WARNING: This kit requires use of the input clutch retainer found in '07-later units (OE part number 04799648AB). All 68RFE should have this retainer. See page 4 for retainer identification and verification measurements.

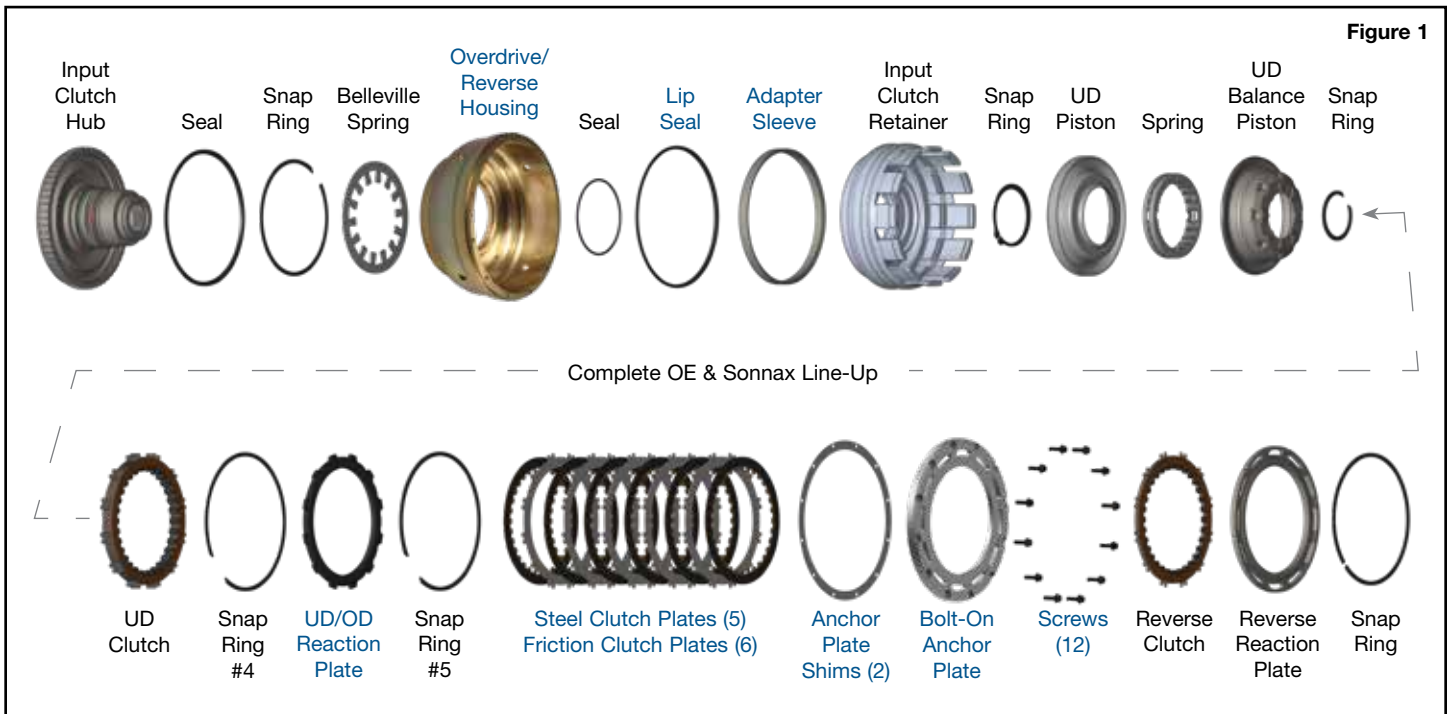

1. Inner Input Clutch Retainer Preparation

- Place adapter sleeve on inner input clutch retainer with 12 marks facing upwards (**Figure 2 & 4**).
- Begin adapter sleeve installation by carefully tapping adapter sleeve with a plastic hammer to get it started, or by heating adapter sleeve and placing it on the inner input clutch retainer.
- Finish adapter sleeve installation by using the old overdrive/reverse housing as a driver to push the adapter sleeve into place until lightly seated (**Figure 3A**).
- Verify adapter sleeve is fully seated against retainer housing (**Figure 3B**).
- Using Sonnax diamond point chisel, stake the aluminum inner input clutch retainer at each of the 12 marks on the adapter sleeve (**Figure 4**).

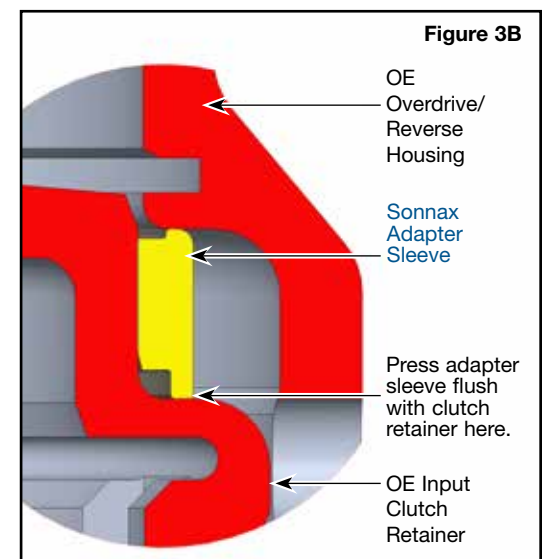
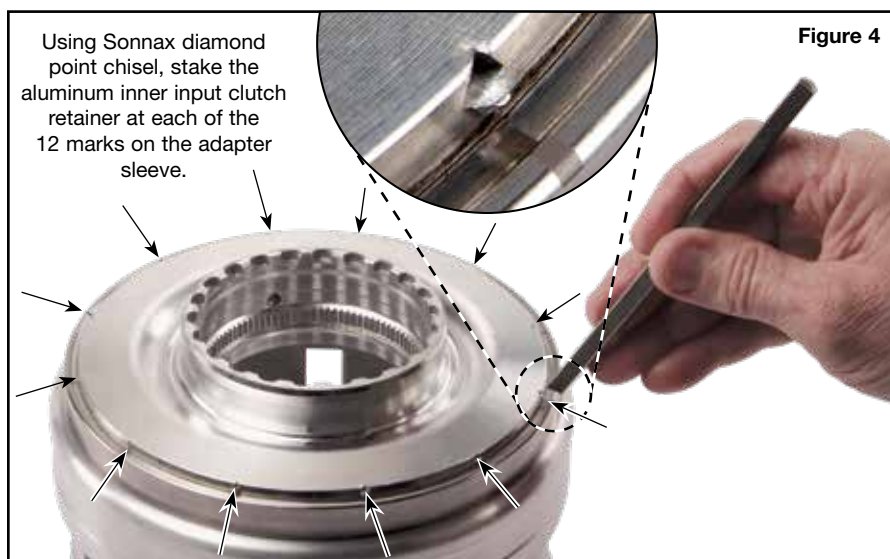
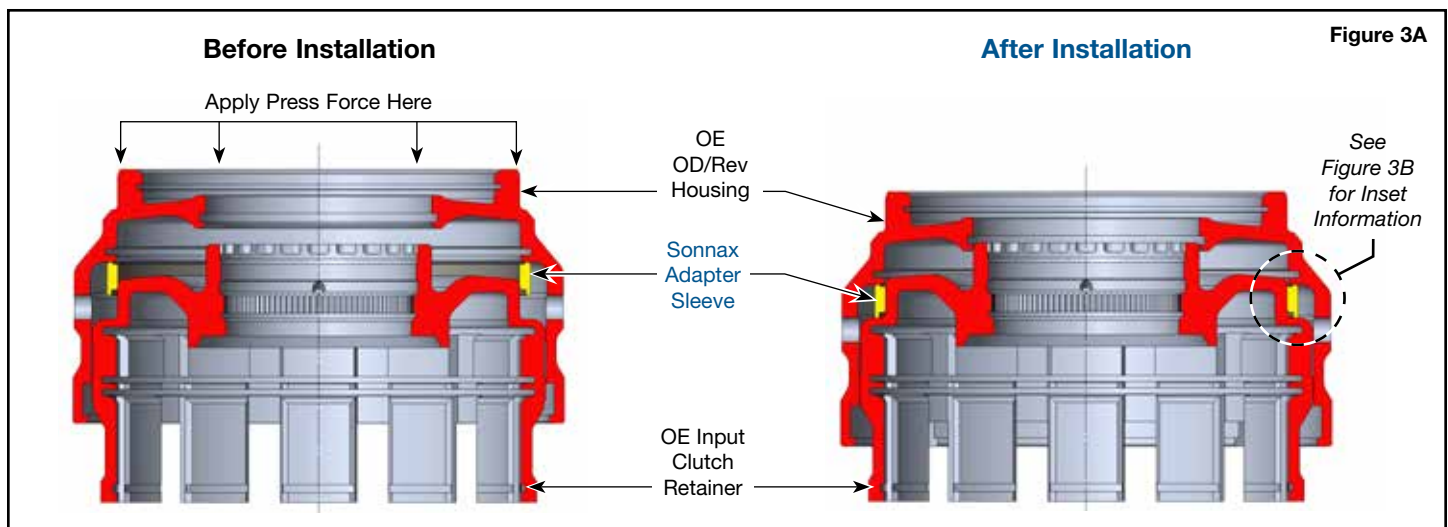
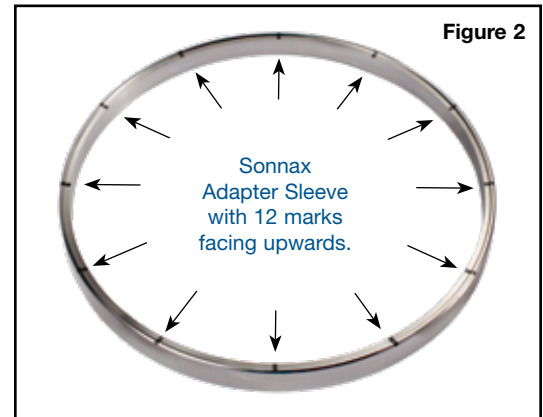

2. Overdrive Clutch Clearance Check

- a. Pre-soak overdrive frictions and steels in ATF+4 transmission fluid before final assembly.
- b. Install OE snap ring number 4 (flat .060" x .190") under Sonnax UD/OD reaction plate.
- c. Install Sonnax UD/OD reaction plate with four 'dots' facing upward (**Figure 5**).
- d. Install OE snap ring number 5 (tapered .095" x .180") above Sonnax UD/OD reaction plate.
- e. Install Sonnax 6 friction plates and 5 steels, beginning with a friction plate and alternating with steel plates.
- f. Place one Sonnax anchor plate shim onto Sonnax overdrive/reverse housing.
- g. Temporarily secure Sonnax bolt-on anchor plate with six of the 12 screws.
- h. Measure overdrive clutch clearance, Mount a dial indicator to the assembly and zero the indicator against the Sonnax bolt-on anchor plate. Apply 20 psi of air pressure to the overdrive clutch and record the indicator reading. OE specification is 0.75-1.61mm (.030-.063").
- i. Add or subtract anchor plate shim to adjust OD clutch clearance if necessary.

3. Final Assembly

- a. Build up complete input clutch housing assembly using normal OE step by step procedures.
- b. Fasten bolt-on anchor plate to Sonnax overdrive/reverse housing with 12 screws. Clean screw threads and threaded holes in housing with brake wash solvent. All threads should be clean and dry prior to assembly. Apply a drop of high strength red Loctite® Threadlocker 262 or equivalent to the threads of each screw and a small amount in each threaded hole in the housing. Install 12 Sonnax screws through the bolt-on anchor plate into the threaded holes in the housing and lightly tighten each screw. If housing has been previously assembled with thread-locking compound, make sure all cured residue is removed from housing, shims and bolt-on anchor plate prior to reassembly.
- c. Torque spec is 51 in-lb. Tighten all screws to lower 40 in-lb value by working around the housing in a crisscross (star) pattern to ensure even pressure on the bolt-on anchor plate. Before the threadlocker cures, retorquing to 51 in-lb specification.

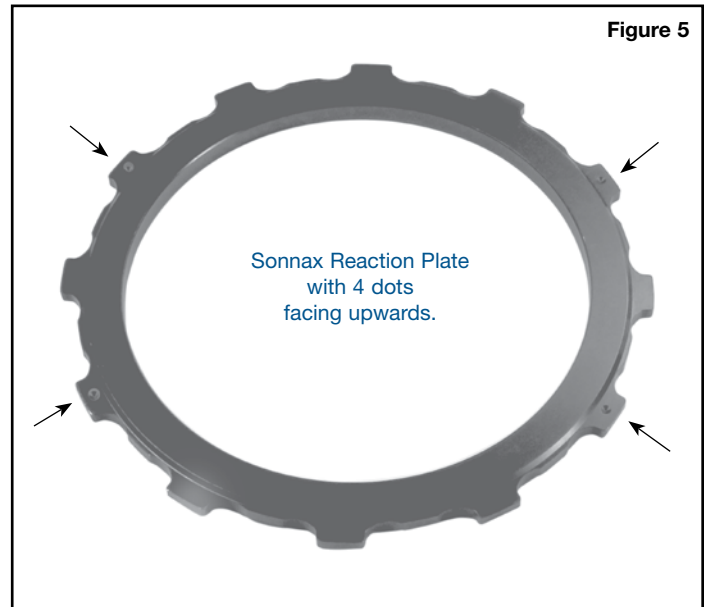

4. Transmission Installation



WARNING: Before test drive, using capable scan tool, perform the clutch volume index (CVI) reset procedure so the control unit can adapt to the OD piston apply area.



WARNING: OEM programming has TCC partially applied with MCC (Modulated Converter Clutch) during shifts. Some aftermarket programming with "2nd gear lock" brings TCC on in 2nd gear and keeps TCC fully applied during 2-3 and 3-4 shifts. This programming combined with increased power and towing applications will put extra stress on the overdrive clutches and reduce durability. Check with scan tool to see if TCC is "on" during 3-4 shift. Inquire with programmer and request option without second gear lock.



NOTE: Due to the 16% larger apply area of the overdrive piston, the overdrive clutch will apply more quickly than OE. As a result it is normal for the OD CVI values to be lower. OE specification for OD CVI is 30-100. With this kit CVI's can be in the low 20's and still be normal.



NOTE: ATF+4 is the recommended fill oil.

5. Retainer Identification & Verification



WARNING: This kit requires use of the input clutch retainer found in '07-later units (OE part number 04799648AB). All 68RFE should have this retainer.

Measure input clutch retainer dimension "A" (Figure 6) and check chamfer (Figure 7) to verify correct input clutch retainer.

