

## Oversized Lockup Control Valve Kit

**Part No.**  
**113741-22K**



- Control Valve
- Spring
- Plunger Valve
- Plunger Sleeve

**NOTE:** Also fits Mitsubishi F1CJA.

## Tool Kit

**Part No.**  
**F-113741-TL22**



- Reamer
- Reamer Jig
- Guide Pin

**NOTE:** Sonnax "F-Tool" kits designed to service a specific bore require the VB-FIX, a self-aligning valve body reaming fixture. More information and instructions can be found online at [www.sonnax.com](http://www.sonnax.com).

## Jatco/Nissan JF011E (RE0F10A)

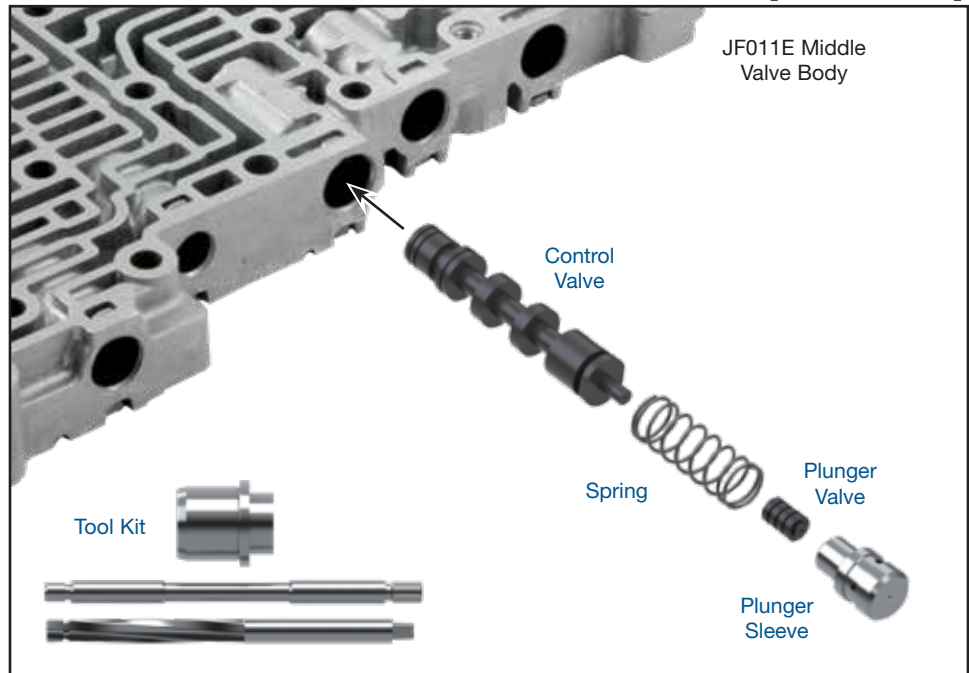

### 1. Disassembly

- Remove OE retainer pin and save for reuse.
- Remove OE lockup control valve train from bore and discard.

### 2. Bore Reaming

Ream lockup control valve bore (for reaming instructions/reamer care, please visit [www.sonnax.com](http://www.sonnax.com)). Sonnax reaming tool kit F-113741-TL22 and VB-FIX are required for this operation.

### 3. Installation & Assembly

- Be certain all debris has been removed from the valve bore and valve body.
- Install Sonnax control valve into reamed bore. Thin valve spool with flats must be outboard.
- Install Sonnax spring included with kit.
- Install Sonnax plunger valve and sleeve assembly with snout inside spring.
- Reinstall OE pin to retain sleeve.

### 4. Final Testing

Vacuum testing at the port(s) indicated holds the recommended minimum 16 and 18 in-Hg.

