



GM 6T30, 6T40 (Gen. 2), 6T45 (Gen. 2), 6T50 (Gen. 2) ZIP KIT®

PART NUMBER 6T40-GEN2-ZIP

QUICK GUIDE

Parts are labeled here in order of installation. See other side of sheet for details on kit contents.

INSTALLATION DIAGRAM

6T40 (Gen. 2)
Control
Valve Body

NOTE: All components of this kit install into the mechatronic unit, and not the pump. Removal of the pump is not required for this kit, unless vacuum testing is to be performed.

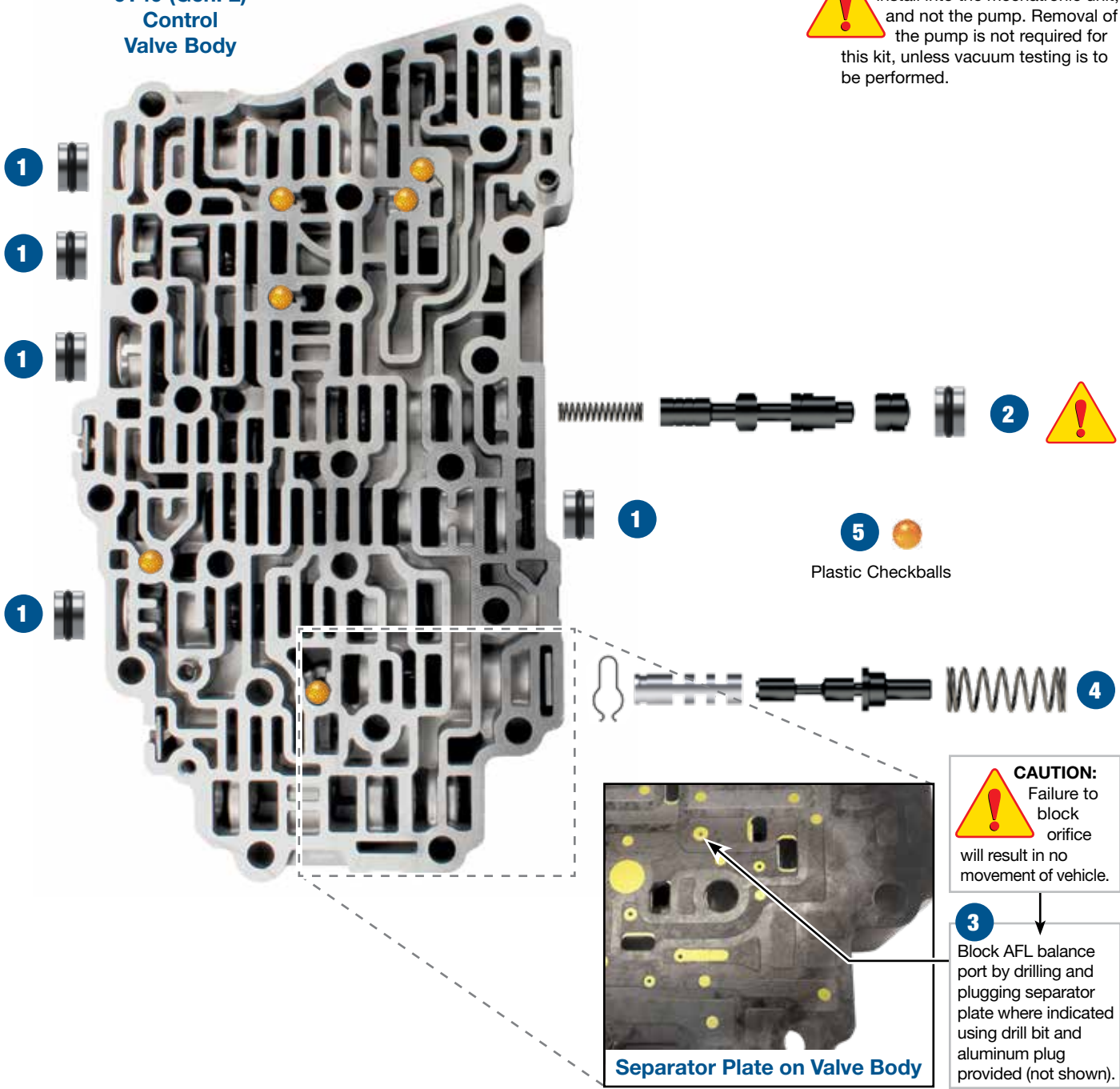

In addition to general rebuilding tips and technical information, the technical booklet included in this kit contains vacuum testing and additional repair options for higher mileage units or for repairing specific complaints which are beyond the scope of this kit.

Kit Contents & Installation Steps

Step 1 Replace 5 OE End Plugs

Place O-ring in groove, lubricate with Sonnax Slippery Stick O-LUBE and roll on bench to size.

Packaging Pocket 1

- End Plugs (5)
- O-Rings (7) 2 extra

Step 2 Replace TCC Regulator Apply Valve Bore Lineup

Remove and discard all OE components except the retainer clip. Save retainer clip for reuse.



CAUTION: The small shuttle valve should be positioned with the rounded end face outboard, and the blind bore inboard.

Packaging Pocket 2

- Spring
- Valve
- Shuttle Valve
- End Plug
- O-Rings (2) 1 extra

Step 3 Block AFL Balance Port

Drill indicated separator plate orifice with included .062" dia. drill bit. Remove any burrs. Insert .062" dia. aluminum plug into drilled hole and peen in place on both sides of plate. Ensure plate will still fit flush on both castings.



CAUTION: Failure to block orifice will result in no movement of vehicle.

Packaging Pocket 3

- Drill Bit, .062" dia.
- Aluminum Plugs, .062" dia. (2) 1 extra



CAUTION: Use care when modifying the balance orifice. Gaskets are bonded to the plates and damage could occur.

Step 4 Replace OE Actuator Feed Limit (AFL) Valve Lineup

Remove and discard OE valve and spring. Save outboard retainer clip for reuse. Install Sonnax sleeve and valve as illustrated. Secure sleeve into bore by installing included clip into sleeve groove at inboard port. Install included spring and secure all into bore with OE retainer.



CAUTION: Ensure supplied retainer clip is fully seated in AFL sleeve groove after installation.

Packaging Pocket 4

- Sleeve
- Valve
- Spring
- Retainer Clip

Step 5 Replace OE Checkballs

Packaging Pocket 5

Checkballs, .250" dia. (6)



GM 6T30, 6T40 (Gen. 2), 6T45 (Gen. 2), 6T50 (Gen. 2) ZIP KIT®

PART NUMBER 6T40-GEN2-ZIP

INSTALLATION & TESTING BOOKLET

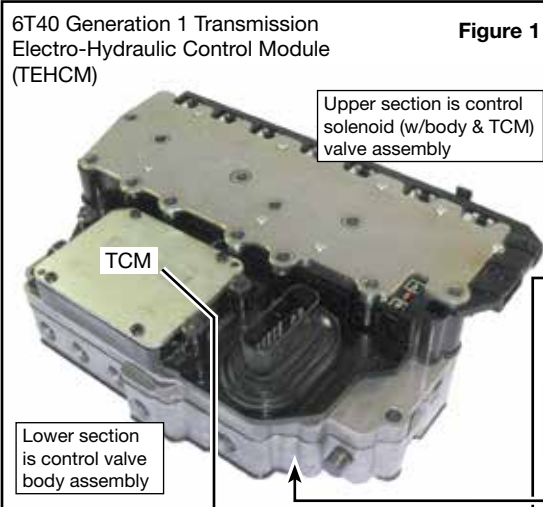

Figure 1

Valve Body Identification

Confirm Generation

This Zip Kit works in 6T30 and Generation 2 6T40 series valve bodies. To identify core as Generation 1 versus Generation 2, check for presence of 4-5-6 clutch boost valve in the control valve body assembly (Figures 1 & 2). The 6T30 is similar to the Generation 2 6T40 series valve bodies, in that it has a 4-5-6 clutch boost valve, no pressure switches, and has a letter as the TCM identifier 8th digit.

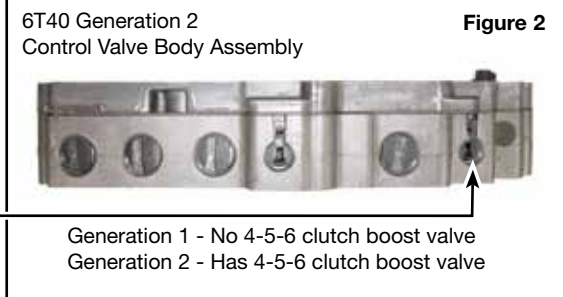

Figure 2

Generation 1 - No 4-5-6 clutch boost valve
 Generation 2 - Has 4-5-6 clutch boost valve

Also check the Transmission Control Module (TCM) identifier (Figures 3 & 4). The control valve body assembly and TCM must be of the same generation.

Adaptive Learning

The 6T30, 6T40, 6T45 and 6T50 are equipped with several adaptive learning strategies. After valve body service the

existing adaptive values will need to be erased. Then, a "Fast Learn" process should be performed. Reference GM material for the proper "Fast Learn" process.

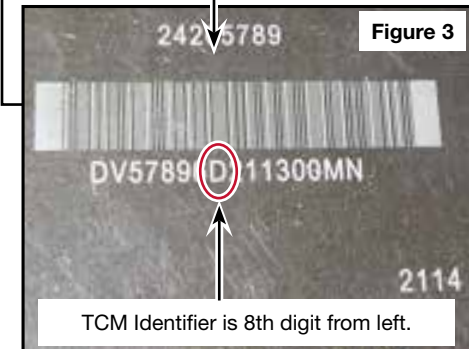

Figure 3

TCM Identifier is 8th digit from left.

TCM Identifier Figure 4

Generation 1	Number
Generation 2	Letter

Solenoids

The 6T30 and Generation 2 6T40, 6T45 and 6T50 solenoids are a mix of normally-high and normally-low type. These are calibrated at the factory and switching solenoids between locations in the control solenoid (w/body and TCM) valve assembly should be avoided.

Solenoid & Clutch Apply Chart

Figure 5

Range/Gear	Shift Solenoid	1-2-3-4 CL PC Sol N.H.	2-6 CL PC Sol N.L.	3-5 Rev. CL PC Sol N.L.	Low Rev. 4-5-6 CL PC Sol N.H.	4-5-6 Clutch	3-5 Reverse Clutch	2-6 Clutch	Low & Rev. CL (DWC)	Low & Rev. Clutch	1-2-3-4 Clutch
Park	On	On	Off	Off	Off					Applied*	
Reverse	On	On	Off	On	Off		Applied			Applied	
Neutral	On	On	Off	Off	Off					Applied*	
Drive	1st Braking	On	Off	Off	Off				Holding [†]	Applied	Applied
	1st	Off	Off	Off	On				Holding		Applied
	2nd	Off	Off	On	Off			Applied			Applied
	3rd	Off	Off	Off	On	On		Applied			Applied
	4th	Off	Off	Off	Off	Off	Applied				Applied
	5th	Off	On	Off	On	Off	Applied	Applied			
6th	Off	On	On	Off	Off	Applied		Applied			

NOTE: For shift solenoids, "ON" = solenoid energized (pressurized), "OFF" = solenoid de-energized (no pressure). For pressure control (PC) solenoids, "ON" = pressurized, "OFF" = no pressure. *Applied with no load. [†]Holding but ineffective.

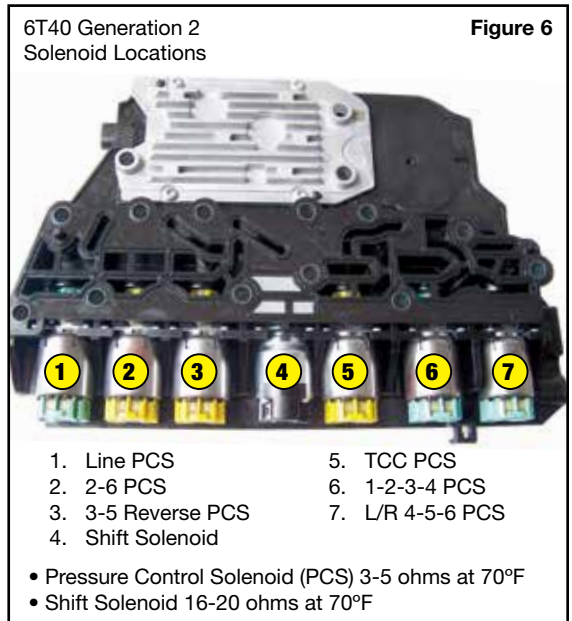
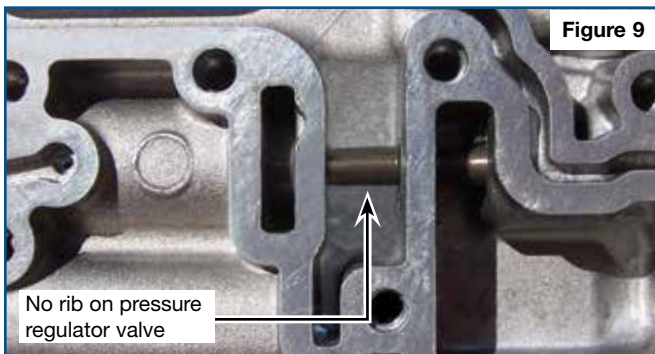

Figure 6

- Pressure Control Solenoid (PCS) 3-5 ohms at 70°F
- Shift Solenoid 16-20 ohms at 70°F

Additional Identification Information

Generation 1



Generation 2

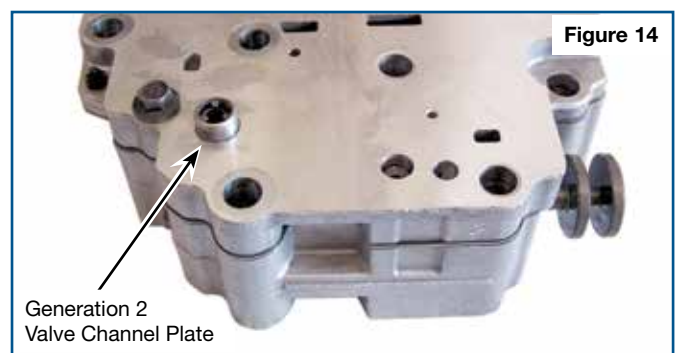
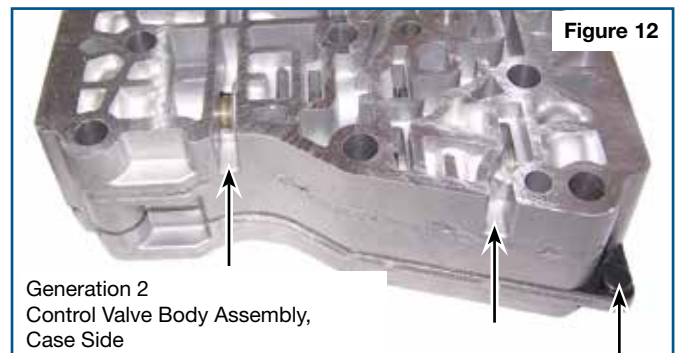
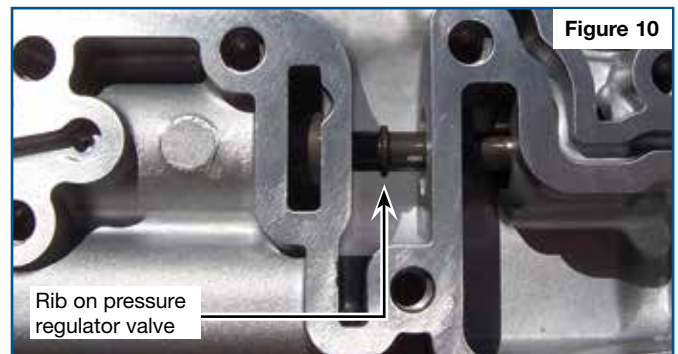
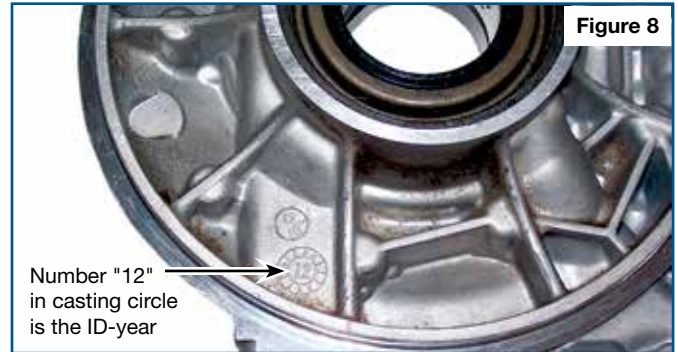

Additional Identification Information

Generation 1

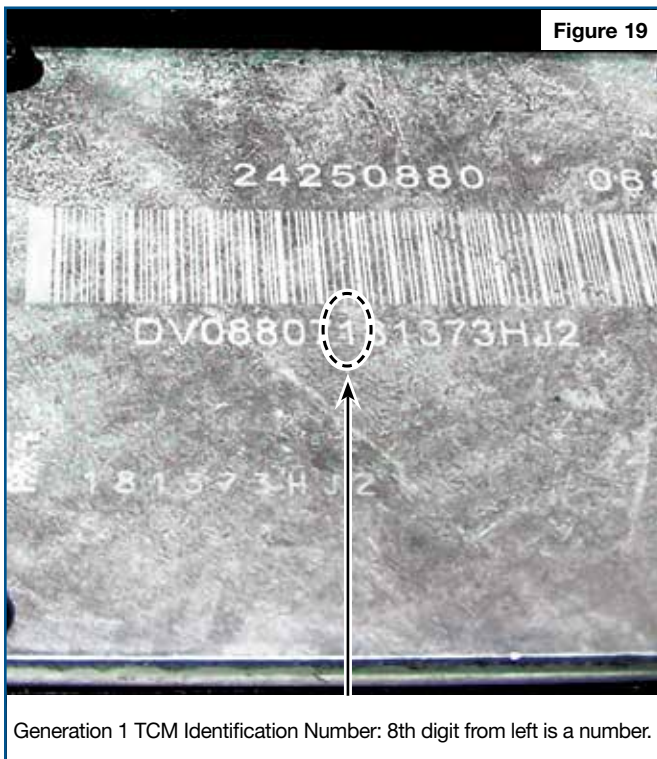
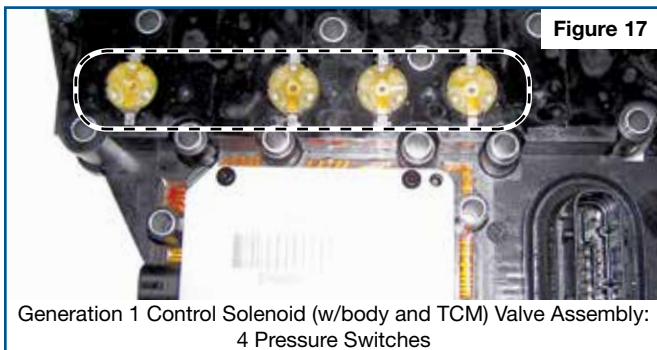
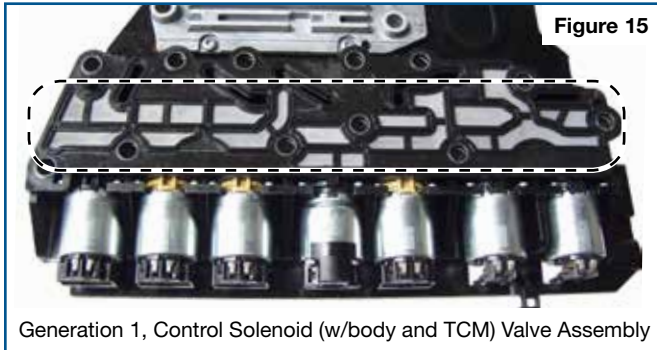

Generation 2

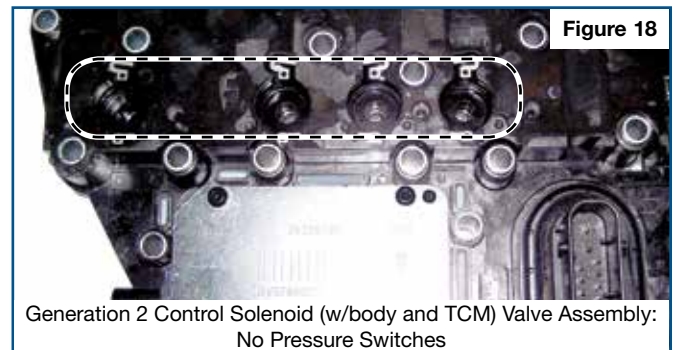

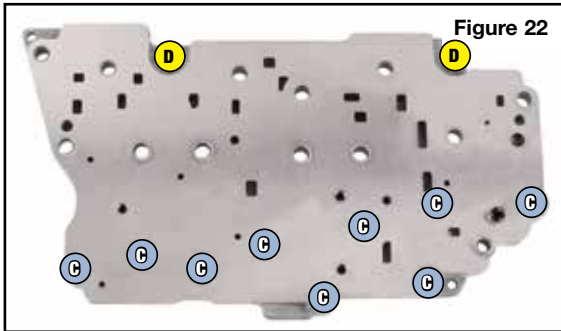
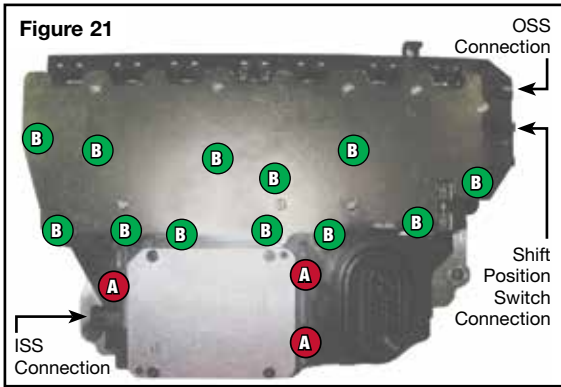

Removal Bolts

Figure 23

Bolt Color Code	Bolt Length	Quantity	Torque Specification
A Red	40.5mm	3	71 in-lb
B Green	30mm	12	106 in-lb
C Blue	60mm	9	97 in-lb
D Yellow	53mm	2	97 in-lb

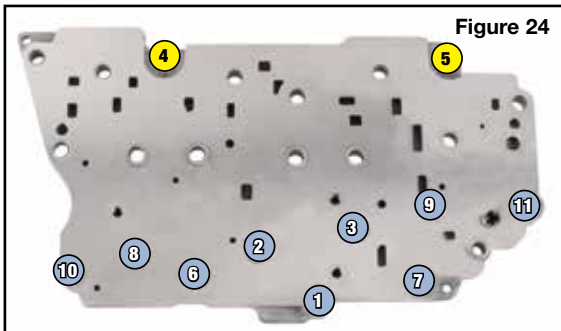

Zip Kit Instructions

1. TEHCM Removal from Case

- Disconnect the input speed sensor, output speed sensor and shift position switch connectors from valve body.
- Remove the three control solenoid (w/body and TCM) valve assembly bolts, 40.5mm long (**Figure 21 & 23**).
- Remove the 12 control solenoid (w/body and TCM) valve assembly bolts, 30mm long (**Figure 21 & 23**).
- Remove the control solenoid (w/body and TCM) valve assembly from control valve body assembly.
- Remove the nine control valve body assembly bolts, 60mm long (**Figure 22 & 23**).
- Remove the two control valve body assembly bolts, 53mm long (**Figure 22 & 23**).
- Remove the control valve body assembly from the case.

2. Installation

Install Zip Kit parts as shown on diagram of separate quick guide sheet included in this Zip Kit. Sonnax recommends vacuum testing critical wear areas not covered by this kit to determine whether additional Sonnax parts are required (see page 3).

3. TEHCM Reinstall into Case

- Install control valve body assembly into case and secure with (2) 53mm and (9) 60mm bolts until finger-tight (**Figure 22**).
- Tighten to 97 in-lbs of torque in the indicated sequence (**Figure 24**).
- Install control solenoid (w/body and TCM) valve assembly to control valve body assembly with (12) 30mm and (3) 40.5mm bolts until finger-tight (**Figure 21**).
- Tighten (12) 30mm bolts to 106 in-lb of torque in the indicated sequence (**Figure 25**).
- Tighten the (3) 40.5mm bolts to 71 in-lb torque in the indicated sequence.
- Reconnect the input speed sensor, output speed sensor and shift position switch connectors (**Figure 21**).



Critical Wear Areas & Vacuum Test Locations

NOTE: OE valves are shown in rest position and should be tested in rest position unless otherwise indicated. Test locations are pointed to with an arrow. Springs are not shown for visual clarity. Low vacuum reading indicates wear and Sonnax parts noted for replacement.

Control Valve Body Assembly – Front • Gen. 2 6T40 Shown

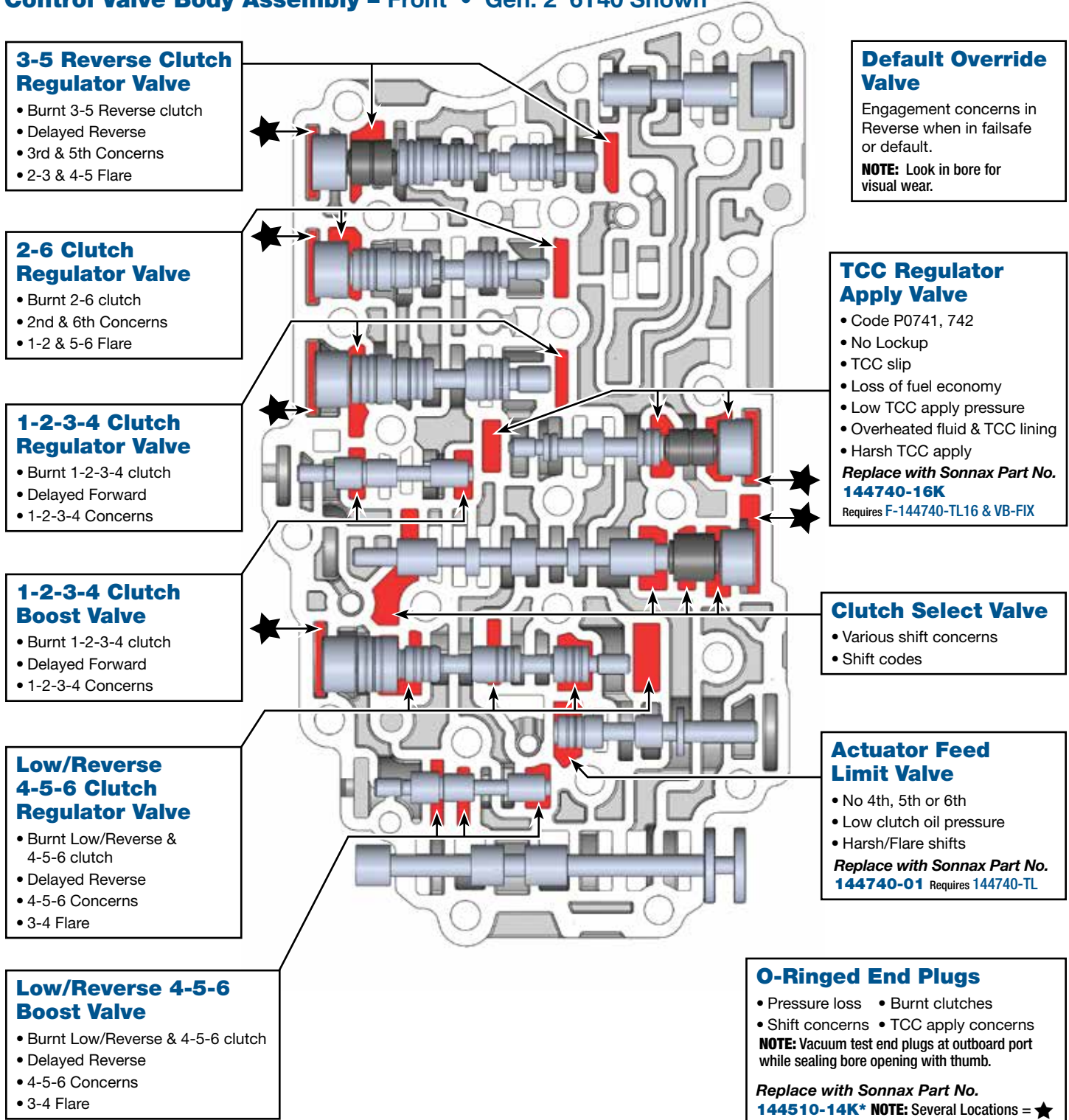

3-5 Reverse Clutch Regulator Valve

- Burnt 3-5 Reverse clutch
- Delayed Reverse
- 3rd & 5th Concerns
- 2-3 & 4-5 Flare

2-6 Clutch Regulator Valve

- Burnt 2-6 clutch
- 2nd & 6th Concerns
- 1-2 & 5-6 Flare

1-2-3-4 Clutch Regulator Valve

- Burnt 1-2-3-4 clutch
- Delayed Forward
- 1-2-3-4 Concerns

1-2-3-4 Clutch Boost Valve

- Burnt 1-2-3-4 clutch
- Delayed Forward
- 1-2-3-4 Concerns

Low/Reverse 4-5-6 Clutch Regulator Valve

- Burnt Low/Reverse & 4-5-6 clutch
- Delayed Reverse
- 4-5-6 Concerns
- 3-4 Flare

Low/Reverse 4-5-6 Boost Valve

- Burnt Low/Reverse & 4-5-6 clutch
- Delayed Reverse
- 4-5-6 Concerns
- 3-4 Flare

Default Override Valve

Engagement concerns in Reverse when in failsafe or default.

NOTE: Look in bore for visual wear.

TCC Regulator Apply Valve

- Code P0741, 742
- No Lockup
- TCC slip
- Loss of fuel economy
- Low TCC apply pressure
- Overheated fluid & TCC lining
- Harsh TCC apply

Replace with Sonnax Part No. 144740-16K
Requires F-144740-TL16 & VB-FIX

Clutch Select Valve

- Various shift concerns
- Shift codes

Actuator Feed Limit Valve

- No 4th, 5th or 6th
- Low clutch oil pressure
- Harsh/Flare shifts

Replace with Sonnax Part No. 144740-01 Requires 144740-TL

O-Ringed End Plugs

- Pressure loss
- Burnt clutches
- Shift concerns
- TCC apply concerns

NOTE: Vacuum test end plugs at outboard port while sealing bore opening with thumb.

Replace with Sonnax Part No. 144510-14K* NOTE: Several Locations = ★

Part numbers with an asterisk () are included in this Zip Kit.

Critical Wear Areas & Vacuum Test Locations

NOTE: OE valves are shown in rest position and should be tested in rest position unless otherwise indicated. Test locations are pointed to with an arrow. Springs are not shown for visual clarity. Low vacuum reading indicates wear and Sonnax parts noted for replacement.

Pump Body • Gen. 2 6T40 Shown

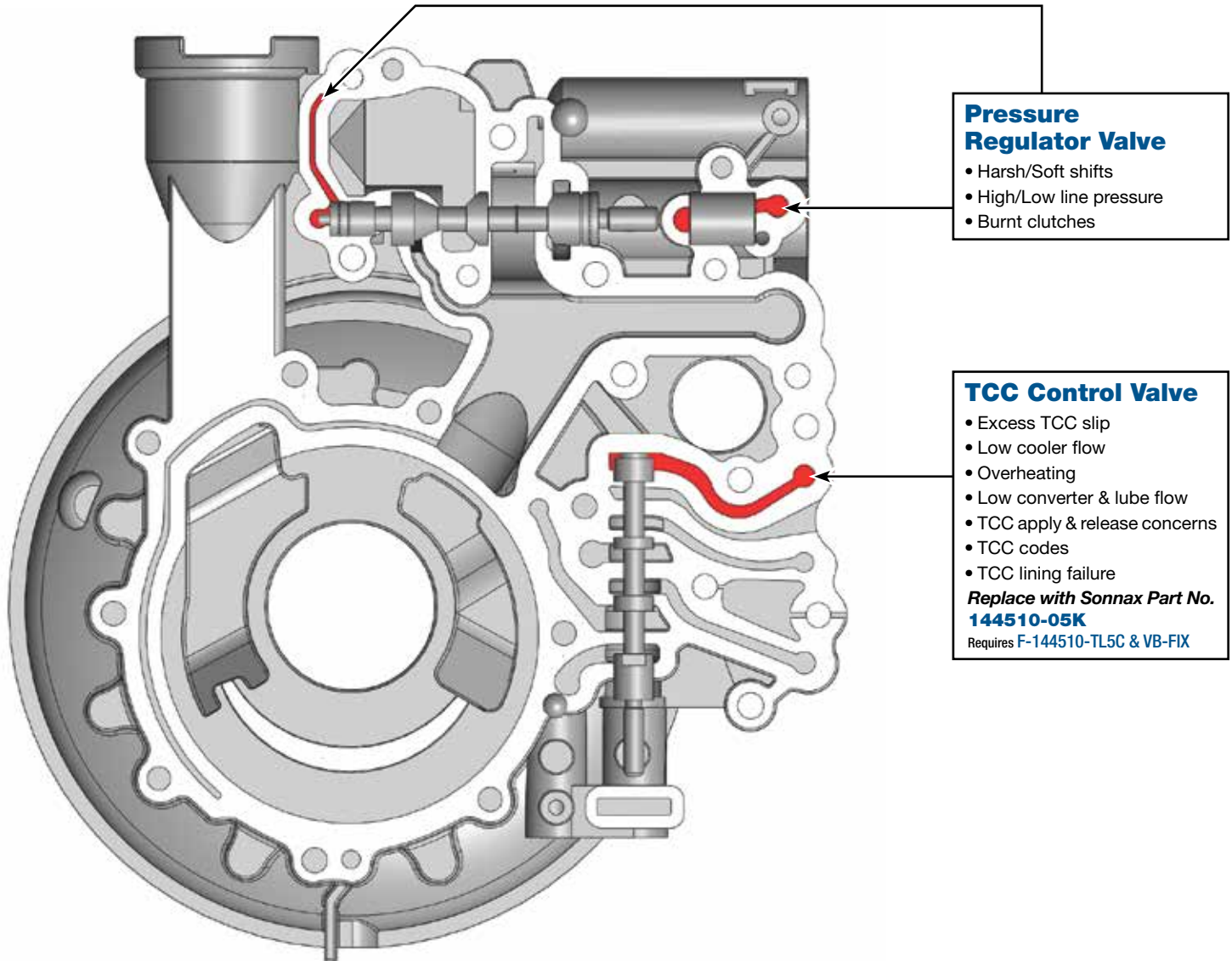

Pressure Regulator Valve

- Harsh/Soft shifts
- High/Low line pressure
- Burnt clutches

TCC Control Valve

- Excess TCC slip
- Low cooler flow
- Overheating
- Low converter & lube flow
- TCC apply & release concerns
- TCC codes
- TCC lining failure

Replace with Sonnax Part No. 144510-05K
Requires F-144510-TL5C & VB-FIX

OE Exploded View

Control Valve Body Assembly • Gen. 2 6T40 Shown

NOTE: Depending upon vehicle application, the OE springs shown may not be present.

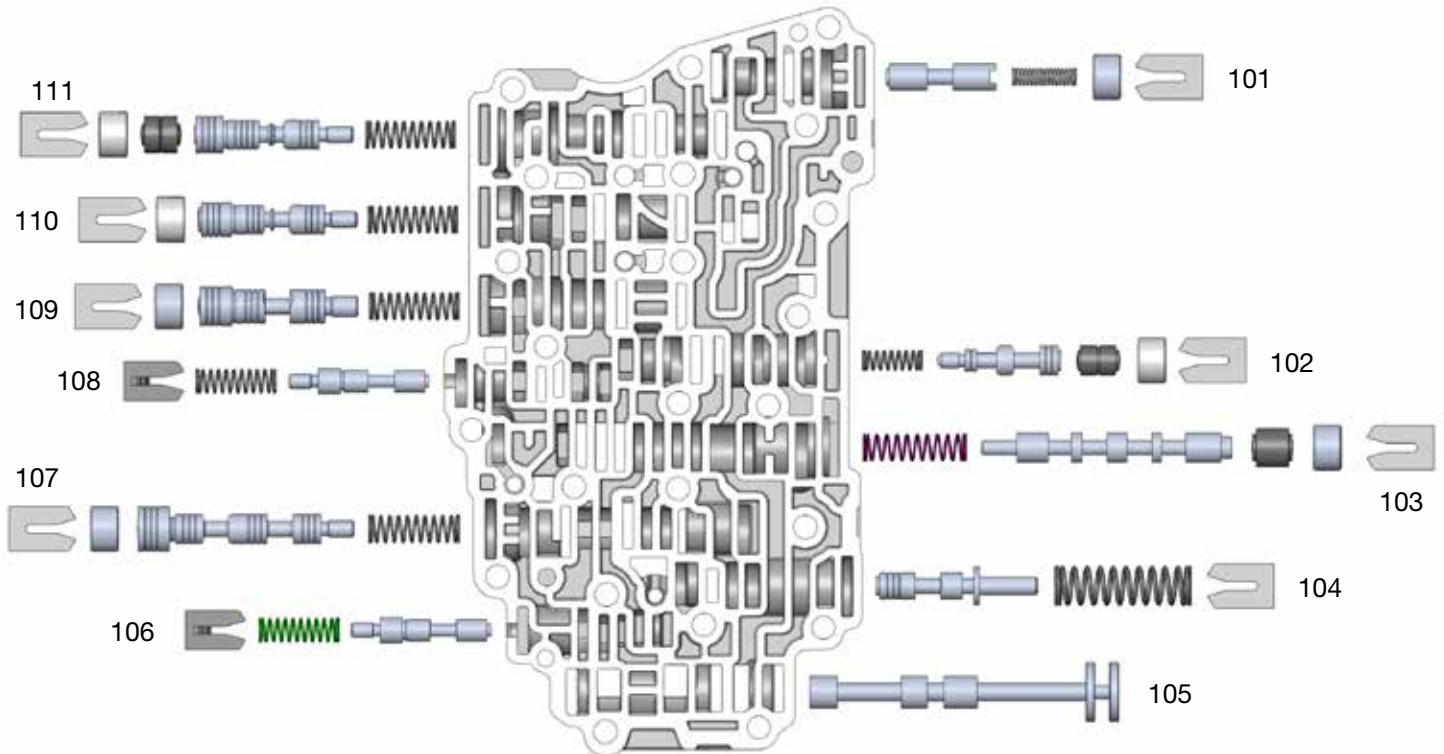

Control Valve Body Assembly Descriptions

I.D. No.	Description
101	Default Override Valve
102	TCC Regulator Apply Valve
103	Clutch Select Valve (inboard) Shuttle Valve (outboard)
104	Actuator Feed Limit Valve
105	Manual Valve
106	Low/Reverse 4-5-6 Boost Valve
107	Low/Reverse & 4-5-6 Clutch Regulator Valve
108	1-2-3-4 Clutch Boost Valve
109	1-2-3-4 Clutch Regulator Valve
110	2-6 Clutch Regulator Valve
111	3-5 Reverse Clutch Regulator Valve

OE Exploded View

Pump Body • Gen. 2 6T40 Shown

NOTE: Depending upon vehicle application, the OE springs shown may not be present.

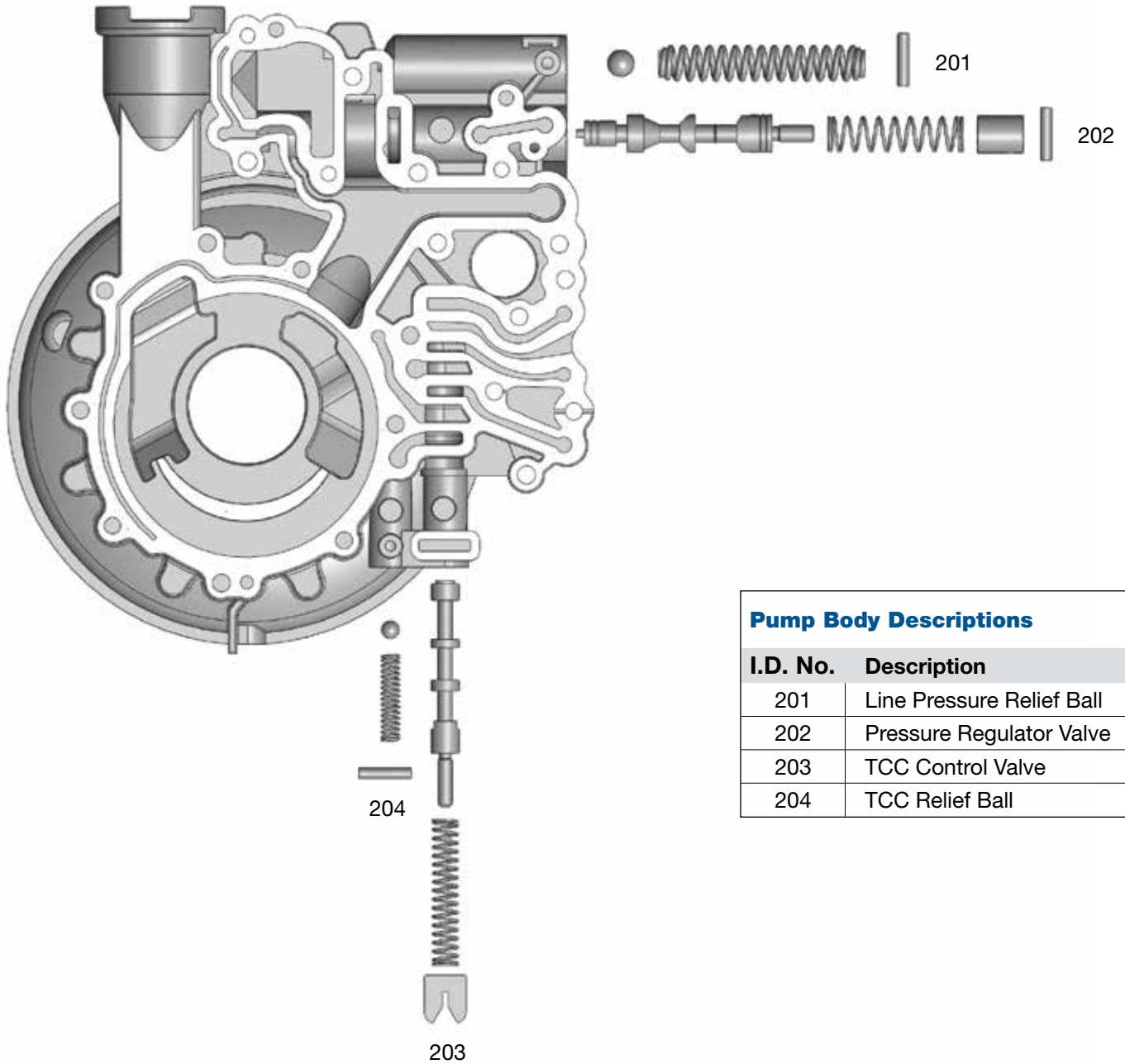

Pump Body Descriptions

I.D. No.	Description
201	Line Pressure Relief Ball
202	Pressure Regulator Valve
203	TCC Control Valve
204	TCC Relief Ball