

Oversized Pressure Regulator Valve & Boost Valve Kit



Part No.
15741-01K

- Pressure Regulator Valve
- Pressure Regulator Spring
- Boost Sleeve
- Boost Valve

Tool Kit



Part No.
F-15741-TL

- Reamer
- Reamer Jig
- Guide Pin

NOTE: Sonnax "F-Tool" kits designed to service a specific bore require the VB-FIX, a self-aligning valve body reaming fixture. More information and instructions can be found online at www.sonnax.com.

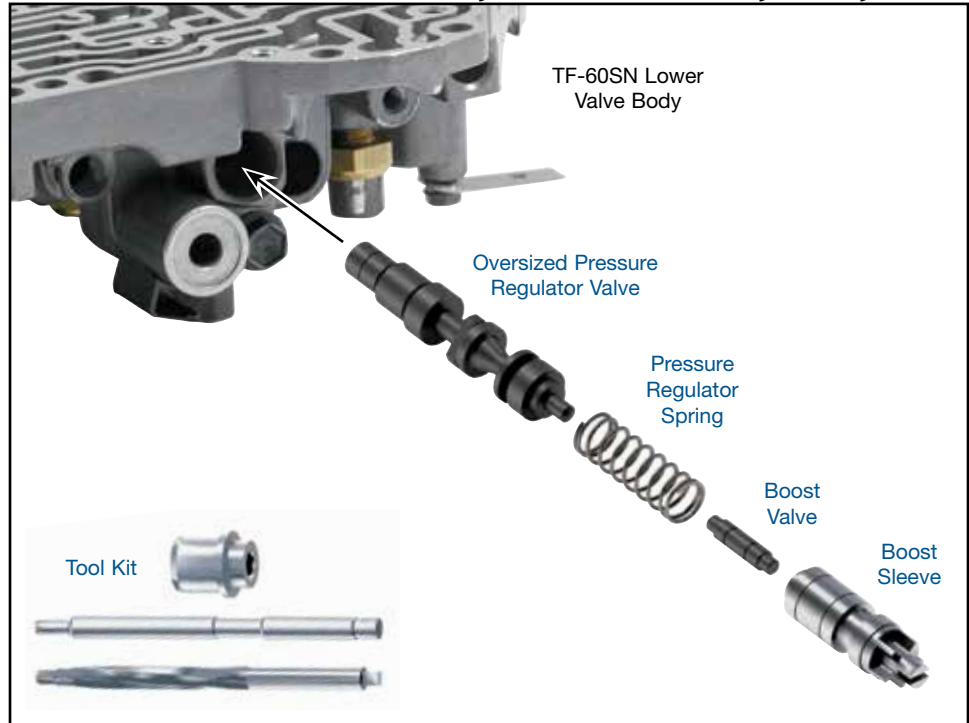

NOTE: Observe and record the step location of retainer on OE sleeve end prior to removal.

1. Disassembly

- Remove and discard OE boost sleeve and valve.
- Remove and discard OE pressure regulator spring and valve.

2. Bore Reaming

Ream pressure regulator bore (for reaming instructions/reamer care, please visit www.sonnax.com). Sonnax reaming tool kit **F-15741-TL** and **VB-FIX** are required for this operation.

3. Installation & Assembly

- Be certain all debris has been removed from the valve bore and valve body.
- Install Sonnax pressure regulator valve, spring, boost valve and sleeve assembly.
- Ensure retainer is set at the same step location on the Sonnax sleeve as it was for the OE sleeve.

4. Final Testing

Vacuum testing at the port(s) indicated holds the recommended minimum 18 in-Hg.

